

INSTRUCTION MANUAL

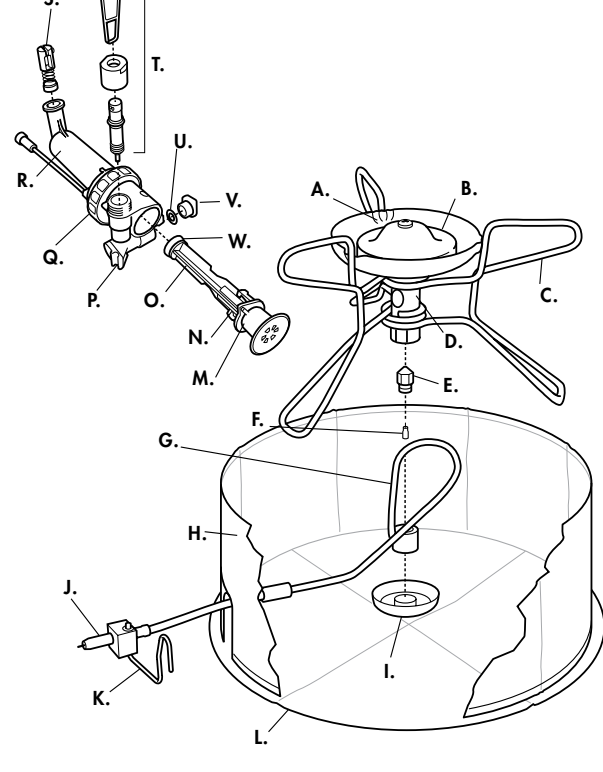

WHISPERLITE™ STOVE

Retain these instructions for future reference.



⚠ DANGER



FOR OUTDOOR USE ONLY

CARBON MONOXIDE HAZARD

This stove can produce carbon monoxide, which has no odor.

Using it in an enclosed space can kill you.

Never use this stove in an enclosed space such as a camper, tent, vestibule, car, or home.

FOR YOUR SAFETY

Do not store or use gasoline or other flammable vapors and liquids in the vicinity of this or any other appliance.



CARBON MONOXIDE, FIRE, EXPLOSION HAZARD

There are serious hazards associated with using this stove and fuel. Accidental fire, explosion, and misuse can cause death, serious burns, and property damage. You are responsible for your own safety and the safety of those in your group. Please use good judgment and read these instructions for use carefully. Familiarize yourself with the stove before connecting it to its fuel bottle. Keep these instructions for future reference.

This stove is a lightweight, compact device made for OUTDOOR USE ONLY to boil water or cook food. Never use it for any other purpose. Cooking outdoors is more hazardous than cooking as you normally would at home. Please consult with your local outdoor retailer to learn more about cooking outdoors. Seek qualified instruction before you venture outdoors.

Follow this safety information:

- Check that the seals between the stove and the fuel bottle are in place and in good condition before connecting the stove to the cylinder. Do not use this stove if it has damaged or worn seals.
- Keep stove and fuel bottle away from other heat sources. If you expose the fuel bottle to high heat, it will explode or leak and you can be killed or seriously burned.
- Follow all warnings on fuel bottle regarding use and storage.
- Do not disassemble stove beyond what is described in these instructions. DO NOT MODIFY THIS STOVE. Disassembly or modification of stove in any manner not consistent with these instructions voids warranty and can result in an unsafe situation where fire, burns, severe injury or death can occur.
- Do not use stove if parts are missing or broken, or with replacement parts not specific to your stove model. Use of stove with missing or broken parts, or with replacement parts not specific to your stove model, can result in an unsafe situation where fire, burns, severe injury or death can occur.

Cascade Designs, Inc. warrants the use of appropriately-sized MSR® brand cookware only—use of cookware other than MSR® brand cookware is at user's own risk and discretion.

WHISPERLITE™ INSTRUCTIONS

⚠ DANGER Do not use this stove: (1) before reading and fully understanding this Instruction Manual; (2) if you are not prepared or comfortable attending to a burning and/or hot stove at all times; (3) if you observe leaking fuel; or (4) if you observe any condition with the stove system or in the surrounding environment that would make operation of an open flame device dangerous. Failure to follow these directions can cause an unsafe situation leading to fire, burns, severe injury or death.

STOVE PARTS	D. Mixer Tube	H. Windscreen	K. Catch Arm
A. Rim detent	E. Jet	I. Priming Cup	L. Heat Reflector
B. Burner Head	F. Shaker Needle	J. Fuel Line (Brass) End	
C. Pot Supports/Legs	G. Generator Tube		
FUEL PUMP PARTS	P. Fuel Pump Groove	Q. Pump Seal	R. Pump body
M. Plunger Bushing	N. Plunger Bushing Tabs	O. Plunger	
	S. Check Valve		
		T. Control Valve Assembly	U. Fuel Tube O-ring
		V. Fuel Tube Bushing	W. Pump Cup

FUEL INFORMATION The WhisperLite™ only burns White Gas.

Use MSR® SuperFuel™ (White Gas) for optimal performance. It is the highest quality fuel available for your stove. Do not use leaded fuels. Fuels other than MSR SuperFuel white gas can lead to rapid stove clogging and require more frequent Jet and Fuel Line cleanings. Also, the use of Unleaded Auto Gas may shorten stove lifespan. Use of stove with non-MSR fuel products is not recommended.

Visit www.msrgear.com for more information on international fuel names and safe stove transportation.

STOVE MAINTENANCE

Deposits in the Jet and Fuel Line reduce fuel flow and impair stove performance. Minor deposits in the Jet can be cleared with the Shaker Needle. Major deposits may require more extensive cleaning of the Jet and Fuel Line. At a minimum, perform the following maintenance annually or every time you perform the Pump Maintenance.

CLEANING THE JET WITH THE SHAKER NEEDLE
 1. Close Pump Control Valve and wait 5 minutes for stove to cool. 2. Shake stove up and down. Shaker Needle inside Jet should rattle. 3. Preheat and run stove. If performance does not improve, perform Cleaning the Jet and Fuel Line steps.

CLEANING THE JET AND FUEL LINE
 1. Fold Pot Supports/Legs to packed position. 2. Unscrew Priming Cup and remove Wick. 3. Hold folded Pot Supports/Legs together. Remove Fuel Line from Mixer Tube. Keep unattached Fuel Line threaded through leg. 4. Rescrew Priming Cup to keep Pot Supports/Legs together. 5. Unscrew Jet with Jet and Cable Tool. IMPORTANT: Do not bend Generator Tube while loosening Jet. 6. Remove Shaker Needle and use it to clear Jet Orifice from top or bottom. 7. Scour Fuel Line. Remove Cable from Fuel Line with Jet and Cable Tool. Stubborn cables can be loosened with a common lubricant (WD-40™, Pump Cup Oil, etc.). Fully reinsert Cable into Fuel Line. Move Cable in and out with 5-inch (13-centimeter) strokes approximately 20 times. Wipe Cable clean. 8. Flush Fuel Line. Remove Cable. Insert Fuel Line into Pump and Fuel Bottle and secure Catch Arm on Fuel Pump Groove. Pressurize Fuel Bottle with 1.5 strokes. Fully open Control Valve to flush 4 spoonfuls of fuel through Fuel Line into an appropriate container. (Jet uninstalled.) **DANGER:** Keep away from ignition sources. Close Control Valve and remove Fuel Line. Safely dispose fuel when flushing is complete. 9. Reassemble stove. If stove performance is still impaired, repeat Cleaning the Jet and Fuel Line steps.

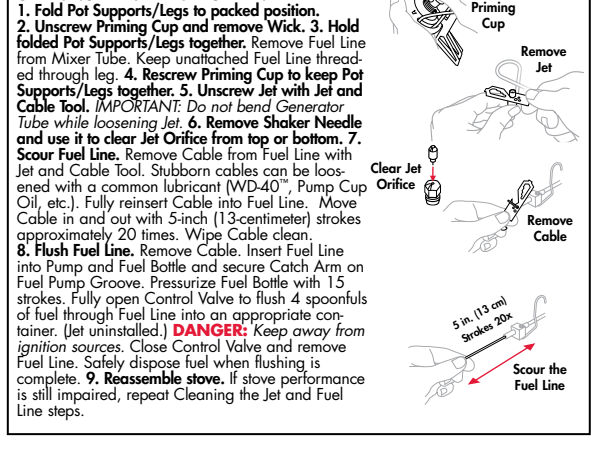

PUMP MAINTENANCE

O-rings can become dry, cracked or torn with use. Their lifespan is affected by dirt, debris, temperature, friction and frequency of use. For this reason, please inspect your O-rings before every trip. Replace dry, cracked, or torn O-rings immediately, and replace all O-rings annually, regardless of appearance. Replacement O-rings and Pump Seals can be found in the Annual Maintenance Kit, or the more comprehensive Expedition Service Kit, purchased separately from an MSR® dealer.

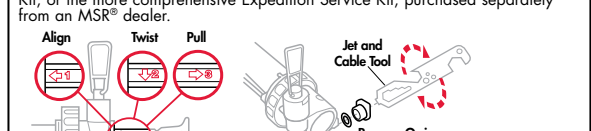

REPLACING FUEL TUBE O-RING
 1. Remove Plunger. Align, twist, and pull. 2. Remove Fuel Tube Bushing and O-ring with Jet and Cable Tool. Remove the O-ring with the end of the Fuel Line or safety pin. 3. Inspect O-ring and replace if damaged. If needed, a spare red Fuel Tube O-ring is provided. 4. Lubricate Pump Cup. Use a drop of pump cup oil or any mineral-based oil. 5. Insert Plunger. Hold thumb and forefinger firmly around Arrow 1. Align Plunger Bushing Tabs with holes in Pump Body. Push Plunger/Bushing into the Pump Body until it snaps in place.

REPLACING CONTROL VALVE O-RING
 1. Unscrew Stop Nut 2 turns. 2. Unscrew Control Valve 6 turns. 3. Unscrew Stop Nut completely and remove Control Valve Assembly. 4. Inspect O-ring and replace if damaged. Remove Control Valve Handle from stem. Slide Stop Nut off. Remove O-ring with safety pin.

REPLACING PUMP SEAL
 Inspect Pump Seal and replace if damaged.
⚠ DANGER If using the MSR maintenance kits, make sure to use the Pump Seal, not an O-ring. Do not add an O-ring under the Pump Seal. Adding an O-ring will cause the pump to leak, which can cause fire, burns, severe injury or death.

CLEANING THE CHECK VALVE
 1. Turn Check Valve Assembly to remove. 2. Wipe any debris from Check Valve and Pump Cavity. 3. Reinsert Check Valve Assembly.
⚠ DANGER Do not disassemble stove or pump beyond what is described in these instructions. Disassembly or modification of stove or pump in any manner not consistent with these instructions voids warranty and can result in an unsafe situation where fire, burns, severe injury or death can occur.

Do not use stove or pump if parts are missing or broken, or with replacement parts not specific to your stove model. Use of stove with missing or broken parts, or with replacement parts not specific to your stove model, can result in an unsafe situation where fire, burns, severe injury or death can occur.

WHISPERLITE™ STOVE OPERATING INSTRUCTIONS

To avoid being killed or seriously injured, READ, UNDERSTAND, AND FOLLOW ALL instructions and warnings in this manual before using this stove. Please familiarize yourself with the parts of your WhisperLite stove. This stove requires a priming or preheating step to convert liquid fuel into vapor to run properly. Priming or preheating the stove is addressed in Step 3.

STOVE PARTS	D. Mixer Tube	H. Windscreen	K. Catch Arm
A. Rim detent	E. Jet	I. Priming Cup	L. Heat Reflector
B. Burner Head	F. Shaker Needle	J. Fuel Line (Brass) End	
C. Pot Supports/Legs	G. Generator Tube		
FUEL PUMP PARTS	P. Fuel Pump Groove	Q. Pump Seal	R. Pump body
M. Plunger Bushing	N. Plunger Bushing Tabs	O. Plunger	
	S. Check Valve		
		T. Control Valve Assembly	U. Fuel Tube O-ring
		V. Fuel Tube Bushing	W. Pump Cup

FUEL BOTTLE PREPARATION The WhisperLite only burns White Gas, see Fuel Information.
 1. Fill Fuel Bottle to fill line only. Air space is necessary for fuel expansion. 2. Insert Pump into Fuel Bottle and firmly tighten. 3. Close the Control Valve, then stroke Plunger (20-30 strokes). Less fuel requires more strokes or pressure. Pump until firm resistance is felt. 4. Check Fuel Bottle for leaks before pressurizing the bottle.

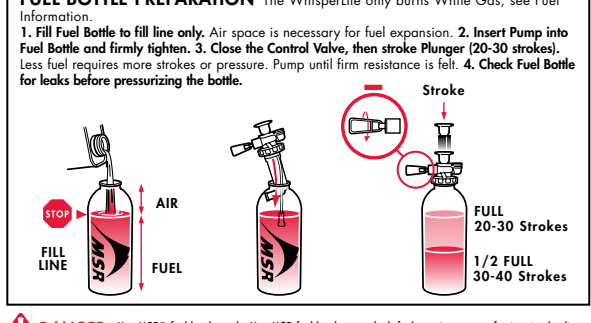

⚠ DANGER Use MSR® fuel bottles only. Non-MSR fuel bottles may leak fuel creating an unsafe situation leading to fire, burns, severe injury or death. Keep children far away from stove and fuel—Cascade Designs, Inc. recommends no less than 10 feet (3-meters). Never leave a burning or hot stove unattended. An unattended stove can lead to fire and/or a situation where children, pets, or the users can be burned, injured, or killed. Use extreme caution when using stove in temperatures below freezing. In freezing temperatures O-rings can stiffen and leak fuel. Always check for fuel leaks before and after pressurizing bottle, priming, and during and after lighting stove. Use of a leaking stove can cause fire, burns, severe injury or death.

1. SET UP STOVE 1. Unfold the 3 Pot Supports/Legs. Snap each Pot Support/Leg into a rim detent. 2. Place stove on the center of the Heat Reflector.

⚠ DANGER Keep combustibles at least 4 feet (1.2 meters) away from the top and sides of a burning stove or a stove that you are in the process of lighting. Keep flammable liquids and vapors at least 25 feet (7.6 meters) away from the top and sides of a burning stove or a stove that you are in the process of lighting. This stove can ignite combustible materials, flammable liquids and vapors creating a situation where fire, burns, severe injury or death can occur. This stove is designed for the outside (i.e., not within enclosure spaces of any kind, e.g., tents) boiling of water or cooking of food only—never use it for any other purpose. Use of stove within any enclosure or for a purpose other than boiling water or cooking food can cause fire, burns, severe injury or death.

2. CONNECT STOVE AND PUMP 1. Lubricate the entire brass end of Fuel Line with saliva or oil. 2. Completely insert the brass end of the Fuel Line into Pump. Place Fuel Bottle on its side so Control Valve points up. 3. Secure Catch Arm on Fuel Pump Groove. Keep Fuel Line straight for safety. Keep Fuel Bottle as far away from stove as possible.

⚠ DANGER Before every use, look for fuel on the fuel bottle, pump, fuel line, burner, and on the area beneath and around stove. Do not light stove if you see a small fire. (See Troubleshooting.) Use of stove where fuel has leaked or is leaking can cause fuel to ignite causing fire, burns, severe injury or death. Never disconnect the fuel line, pump, or fuel bottle when stove is burning, hot, or near any open flame. Never disconnect fuel line, pump, or fuel bottle when control valve is in an open (i.e., fuel flowing) position. Disconnecting fuel line, pump, or fuel bottle when stove is burning, hot, or near any open flame, or disconnecting fuel line, pump, or fuel bottle when control valve is in an open (i.e., fuel flowing) position can lead to spilled fuel that can ignite and cause fire, burns, severe injury or death.

3. PREHEAT STOVE 1. Release only 1/2 spoonful of fuel. Open Pump Control Valve 1.5 turns and let fuel flow through the Jet. Close Pump Control Valve. Look for fuel in Priming Cup. 2. Light fuel in Priming Cup. A brief soccer ball-sized flame is normal.

⚠ DANGER Never place your head or body above the stove while priming, lighting, or cooking. Because stove maintains an open flame, placement of head or body above stove is an unsafe practice that can cause fire, burns, severe injury or death. Never use excess fuel to preheat stove. Use of excess fuel for priming can lead to leaking or spilled fuel that can cause fire, burns, severe injury or death.

4. TURN STOVE ON 1. Wait for preheat flame to reduce in size (approximately 2 minutes). If flame goes out, wait 5 minutes for stove to cool before relighting. 2. Open Pump Control Valve 1/2 turn and wait for steady blue flame. 3. Slowly open Pump Control Valve.

⚠ DANGER Never relight a heated stove to cause large flames that can cause fire, burns, severe injury or death. Never move a burning or hot stove. Always extinguish stove and cool for at least 5 minutes before moving. Moving a burning or hot stove can cause fire, burns, severe injury or death.

5. USE STOVE TO COOK 1. Set up Windscreen. Fold the ends of Windscreen together. Leave a 1-inch (2.5-cm) gap between Windscreen and pot for optimal performance. Ensure that combustion flow and ventilation air are free of any obstruction. Use Windscreen to improve performance in all conditions. 2. Add appropriate food or liquid to cookware. 3. Place cookware onto center of stove. 4. Maintain Fuel Bottle pressure. Add approximately 10 strokes every 10 minutes to maintain performance. Hold Fuel Bottle firmly while pumping.

⚠ DANGER Keep fuel bottle away from the stove burner and other heat sources. Position connected fuel bottle so that it is as far away from the burner as possible. Use of bottle near burner or other heat sources can result in the fuel bottle exploding and causing fire, burns, severe injury or death. Never use cookware with a diameter greater than 10 inches (25 centimeters). Never place and operate two or more stoves together. Never operate stove with empty or dry cookware. Never use non-MSR® reflectors or diffusers. Use of stove in any of the preceding manners can result in the fuel bottle exploding and causing fire, burns, severe injury or death. Never use cookware of any size that is ill-suited or inappropriate for use with stove or stove pot supports (e.g., cookware with a convex or concave bottom, some enamel cookware, etc.). Use of stove with ill-suited and/or inappropriate cookware can result in cookware and/or stove instability and a situation where hot cookware and/or cookware contents can spill and cause fire, burns, severe injury or death. Cascade Designs, Inc. warrants the use of appropriately sized MSR® brand cookware only—use of cookware other than MSR® brand cookware will be at user's own risk and discretion.

6. TURN STOVE OFF 1. Close Pump Control Valve. 2. After flames are out, wait 5 minutes for stove to cool. 3. Unlock Catch Arm and remove Fuel Line from Pump. 4. Depressurize Fuel Bottle and repack stove. Hold Fuel Bottle upright, away from your face and any sources of heat or ignition. Slowly unscrew pump to depressurize Fuel Bottle. NOTICE: To transport the Fuel Bottle, the Pump may be left inside a depressurized Fuel Bottle. The Pump can also be removed and replaced with the Fuel Bottle Cap.

⚠ DANGER Always store fuel bottle with cap securely tightened where it cannot be accessed by children. Storage of fuel bottle with loose cap and/or where accessible by children can result in a child obtaining possession of fuel bottle and accessing bottle contents. Exposure to bottle contents topically and/or by ingestion can cause poisoning, severe injury, or death. Always store fuel in a well-ventilated location away from any possible heat or ignition source such as water heaters, stoves, pilot lights, or furnaces. Fuel fuel bottle near any heat or ignition source can result in the fuel bottle exploding and causing fire, burns, severe injury or death.

Leaking Fuel	Cause	Solution
At Pump and Fuel Bottle Connection	Damaged or missing Pump Seal	Replace Pump Seal
At Pump and Fuel Line Connection	Damaged or missing Fuel Tube O-ring	Replace Fuel Tube O-ring
At Control Valve Stem	Damaged or missing Control Valve O-ring	Replace Control Valve O-ring
In Pump Plunger Chamber	Obstructed Check Valve	Clean Check Valve Cavity
Poor Performance	Cause	Solution
Pump not pressurizing Fuel Bottle	Loose or non-MSR sealed Pump on Fuel Bottle	Tighten or rescrew Pump on Fuel Bottle
	Damaged Pump Cup	Replace Pump Cup
Plunger hard to pump	Dry Pump Cup	Lubricate Pump Cup
Erratic yellow flames	Improper preheating	Repeat Step 3
Diminished flames	Low Fuel Bottle pressure	Pump the Plunger
Slow boil times	Clogged Jet or Fuel Line	Clear Jet and clean Fuel Line
Diminished flames at altitude	Insufficient airflow	Open Windscreen slightly

Limited Warranty details at msrgear.com/warranty
 For Troubleshooting Solutions, visit: msrgear.com/whisperlite

FOR OUTDOOR USE ONLY

MSR
 MOUNTAIN SAFETY RESEARCH®
 ©2018 Cascade Designs, Inc.
 4000 First Avenue South,
 Seattle, WA 98134 USA
 Cascade Designs, Inc., USA - 1-800-531-9531 or 206-505-9500
 Cascade Designs, Inc., Ireland - (+353) 21-4621400
www.msrgear.com | info@cascaadedesigns.com